

Important: Read all instructions prior to installation.

8" Architectural LED Downlight

Dimensional Drawing



8" Architectural LED Downlight

Installation Manual

Cat# 72691-72694

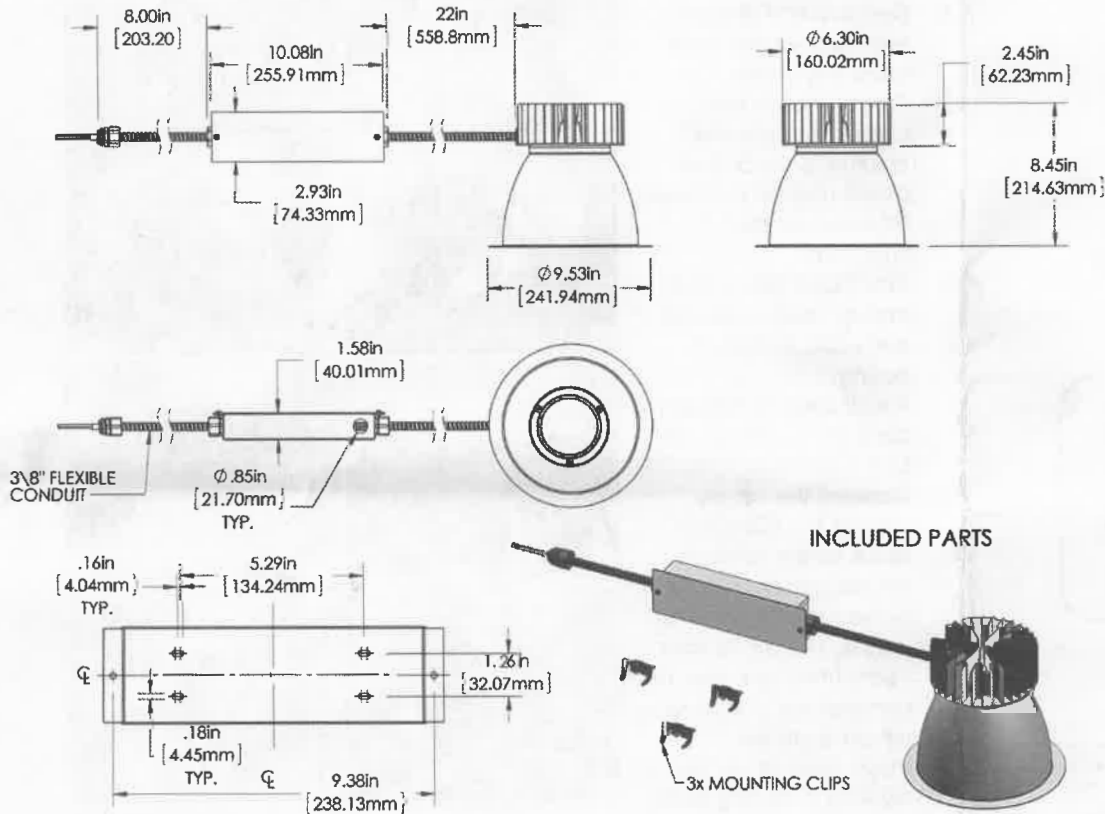

How to install mounting clips

If fixture is loose, install 3 retaining clips on recessed can mounting frame to secure.

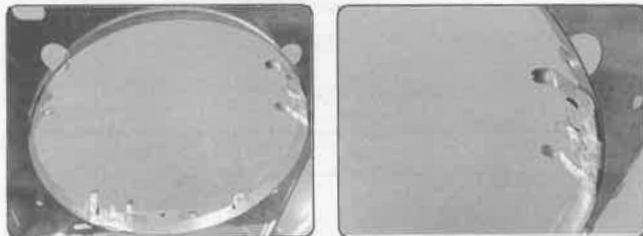

8" Architectural LED Downlight

Cat# 72691 Thru 72694



Safety and Notes

1. Read all instructions completely before beginning. Keep these instructions for future reference.
2. To reduce risk of fire and over-heating, make sure all connections are tight.
3. Turn off the electrical power before proceeding.

CAUTION: Risk of Fire or Electric Shock
 LED Retrofit Kit installation requires knowledge of luminaire electrical systems. If not qualified, do not attempt installation. Contact a qualified person.

WARNING - Install these kits only in properly sized housings that have the construction features and dimensions shown in the photographs and/or drawings.

Retrofit Kit Contents
 LED Fixture
 LED Driver Box
 3 - Retaining Clips

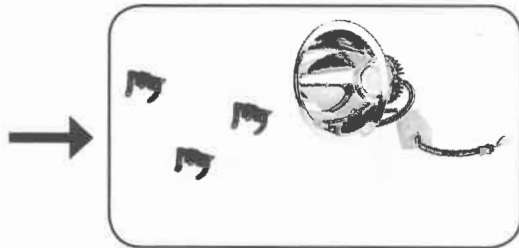

Wiring Diagram

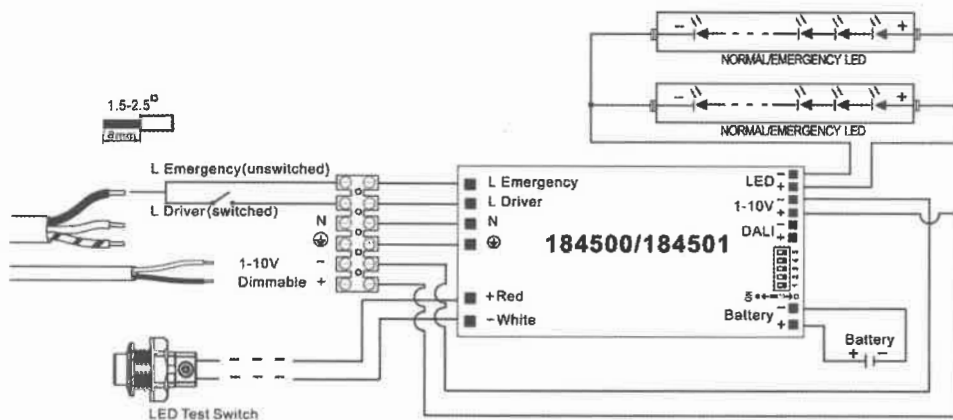

Installation Instructions

NOTE: RETROFIT KIT IS VOLTAGE SPECIFIC. VERIFY VOLTAGE IS between 100~277V BEFORE INSTALLATION

1. Turn off power to fixture, then remove existing lamp.
2. Remove and discard existing reflector from mounting frame.
3. Open junction box.
4. Cut all supply wires leading to the ballast. (wires may be removed)
5. Remove conduit knockout.
6. Insert LED Driver box through ceiling cut-out and allow to rest on ceiling.
7. Install driver box supply conduit into the junction box.
8. Connect the supply voltage to LED driver. Black to line, white to neutral, green to ground. Close junction box. If using 0~10V dimmer, open driver box and make connections gray to gray, purple to purple.
9. Push reflector up through existing mounting frame. If fixture is loose, install 3 retaining clips on mounting frame to secure.

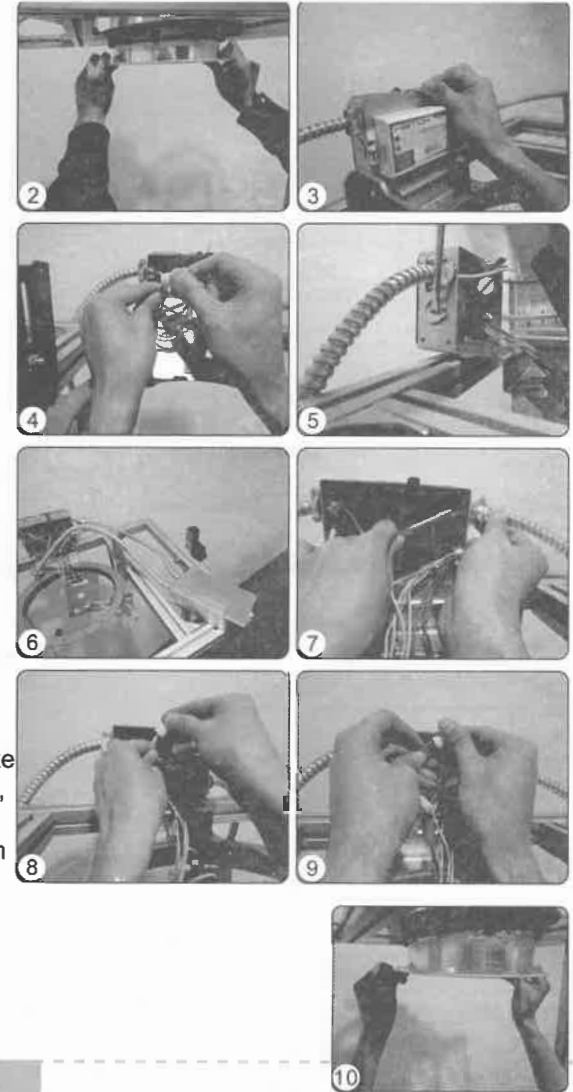

Housing Compatibility



Cat.#	A	B	C
72691-72694	7.9" (200.66 mm)	9.53" (242.06 mm)	8.45" (214.63 mm)